



YB2 系列隔爆型三相异步电动机

YB2 SERIES EXPLOSION-PROOF THREE-PHASE INDUCTION MOTORS

机座号 63~355
防护等级 IP55

功率 0.12~315kW
绝缘等级 F级

适用于: 含有甲烷等气体或煤尘的煤矿井下（非采掘工作面）(Ex d I) 及工厂 (Ex d II AT4、d II BT4) 含有 II 类 A、B 级 T1~T4 组的可燃性气体或蒸汽与空气形成的爆炸性混合物的场所。

Applications: Ideal for the coal mine where methane and coal dust may be present (Ex d I) and dangerous explosion areas (Ex d II AT4、d II BT4) in the plant with the class II A, II B and temperature T1~T4 flammable gas.

特点: 防爆标志为 Exd I、Exd II AT4、Exd II BT4, I 类的最高表面温度不超过 150℃ (当电机表面可能堆积煤尘时), 不超过 450℃ (当电机表面不会堆积或采取措施可以防止堆积煤尘时); II 类的最高表面温度应不超过: T1 (450℃)、T2 (300℃)、T3 (200℃)、T4 (135℃); 接线盒可分别制成三个或六个出线端子, 适用于橡胶套电缆 (或塑料电缆) 和钢管布线两种结构。

Features: all ratings Class I, Class II A & II B and Group T4, Cast iron conduit-box with three or six terminals for rubber jacket cable and steel conduit entry.

环境温度: 环境温度为 -15℃~35℃ (煤矿井下) 或 -15℃~40℃ (工厂)
Ambient temperature: -15℃~35℃ in coal mine and -15℃~40℃ in plant.

额定电压: 380V、660V、380/660V.



性能数据 Performance Data

380V 50Hz

型号 Type	功率 kW	额定 电流 Current A	转速 r/min	效率 Eff. %	功率因数 Power factor	堵转转矩 额定转矩 <u>Locked Rotor Torque</u> Rated Torque	堵转电流 额定电流 <u>Locked Rotor Current</u> Rated Current	最大转矩 额定转矩 <u>Breakdown Torque</u> Rated Torque
同步转速 3000 r/min								
YB2-631-2	0.18	0.53	2720	66.0	0.80	2.2	5.0	2.3
YB2-632-2	0.25	0.69	2720	68.0	0.81	2.2	5.0	2.3
YB2-711-2	0.37	0.99	2740	70.0	0.81	2.2	5.5	2.3
YB2-712-2	0.55	1.4	2740	73.0	0.83	2.2	5.5	2.3
YB2-801-2	0.75	1.8	2845	75.0	0.83	2.2	6.0	2.3
YB2-802-2	1.1	2.6	2845	78.0	0.84	2.2	6.0	2.3
YB2-90S-2	1.5	3.4	2840	79.0	0.84	2.2	7.0	2.3
YB2-90L-2	2.2	4.9	2840	81.0	0.85	2.2	7.0	2.3
YB2-100L-2	3	6.3	2860	83.0	0.88	2.2	7.0	2.3
YB2-112M-2	4	8.1	2880	85.0	0.88	2.2	7.0	2.3
YB2-132S1-2	5.5	11.0	2900	86.0	0.88	2.2	7.5	2.3
YB2-132S2-2	7.5	14.9	2900	87.0	0.88	2.2	7.5	2.3
YB2-160M1-	11	21.3	2930	88.0	0.88	2.2	7.5	2.4



型号 Type	功率 kW	额定 电流 Current A	转速 r/min	效率 Eff. %	功率因数 Power Factor	堵转转矩 额定转矩 Locked Rotor Torque Rated Torque	堵转电流 额定电流 Locked Rotor Current Rated Current	最大转矩 额定转矩 Breakdown Torque Rated Torque
同步转速 3000 r/min								
YB2-160M2-	15	28.8	2930	89.0	0.89	2.2	7.5	2.4
YB2-160L-2	18.5	34.7	2930	89.0	0.89	2.2	7.5	2.4
YB2-180M-2	22	41.0	2940	90.5	0.90	2.0	7.5	2.3
YB2-200L1-2	30	55.5	2950	91.2	0.90	2.0	7.5	2.4
YB2-200L2-2	37	67.9	2950	92.0	0.90	2.0	7.5	2.4
YB2-225M-2	45	82.3	2960	92.5	0.90	2.0	7.5	2.3
YB2-250M-2	55	100	2965	92.5	0.90	2.1	7.5	2.3
YB2-280S-2	75	135	2970	93.2	0.91	2.0	7.5	2.3
YB2-280M-2	90	160	2970	93.8	0.91	2.1	7.5	2.3
YB2-315S-2	110	195	2975	94.0	0.91	1.8	7.0	2.3
YB2-315M-2	132	233	2975	94.5	0.91	1.8	7.0	2.3
YB2-315L1-2	160	279	2975	94.6	0.92	1.8	7.0	2.3
YB2-315L2-2	200	348	2975	94.8	0.92	1.8	7.0	2.3
YB2-355S1-2	185	323	2980	94.6	0.92	1.8	7.0	2.3
YB2-355S2-2	200	348	2980	94.8	0.92	1.8	7.0	2.3
YB2-355M1-	220	383	2980	94.8	0.92	1.6	7.0	2.4
YB2-355M2-	250	433	2980	95.3	0.92	1.6	7.0	2.4
YB2-355L1-2	280	485	2980	95.3	0.92	1.6	7.0	2.4
YB2-355L2-2	315	544	2980	95.6	0.92	1.6	7.0	2.4
同步转速 1500 r/min								
YB2-631-4	0.12	0.44	1310	58.0	0.72	2.0	4.0	2.2
YB2-632-4	0.18	0.62	1310	63.0	0.73	2.0	4.0	2.2
YB2-711-4	0.25	0.79	1330	66.0	0.74	2.0	4.0	2.2
YB2-712-4	0.37	1.12	1330	69.0	0.75	2.0	4.0	2.2
YB2-801-4	0.55	1.6	1390	71.0	0.75	2.4	5.0	2.3
YB2-802-4	0.75	2.0	1390	73.0	0.77	2.4	5.0	2.3
YB2-90S-4	1.1	2.9	1390	75.0	0.77	2.3	6.0	2.3
YB2-90L-4	1.5	3.7	1390	78.0	0.79	2.3	6.0	2.3
YB2-100L1-4	2.2	5.2	1410	80.0	0.81	2.3	6.0	2.4
YB2-100L2-4	3	6.8	1410	82.0	0.82	2.3	6.0	2.4
YB2-112M-4	4	8.8	1440	84.0	0.82	2.3	6.0	2.4
YB2-132S-4	5.5	11.8	1440	86.0	0.84	2.3	7.0	2.4
YB2-132M-4	7.5	15.6	1440	87.0	0.85	2.3	7.0	2.4
YB2-160M-4	11	22.3	1460	88.0	0.85	2.2	7.0	2.4
YB2-160L-4	15	30.1	1460	89.0	0.85	2.2	7.0	2.4
YB2-180M-4	18.5	36.1	1470	90.5	0.85	2.2	7.0	2.3
YB2-180L-4	22	42.7	1470	91.2	0.85	2.2	7.0	2.3



型号 Type	功率 kW	额定 电流 Current A	转速 r/min	效率 Eff. %	功率因数 Power Factor	堵转转矩 额定转矩 Locked Rotor Torque Rated Torque	堵转电流 额定电流 Locked Rotor Current Rated Current	最大转矩 额定转矩 Breakdown Torque Rated Torque
同步转速 1500 r/min								
YB2-200L-4	30	57.6	1470	92.0	0.86	2.2	7.2	2.4
YB2-225S-4	37	69.9	1475	92.5	0.87	2.2	7.2	2.4
YB2-225M-4	45	84.7	1475	92.8	0.87	2.2	7.2	2.4
YB2-250M-4	55	103	1480	93.0	0.87	2.2	7.2	2.4
YB2-280S-4	75	140	1480	93.8	0.87	2.2	7.2	2.4
YB2-280M-4	90	167	1480	94.2	0.87	2.2	7.2	2.4
YB2-315S-4	110	201	1480	94.5	0.89	2.1	7.0	2.4
YB2-315M-4	132	240	1480	94.8	0.89	2.1	7.0	2.4
YB2-315L1-4	160	288	1480	95.0	0.90	2.1	7.0	2.4
YB2-315L2-4	200	359	1480	95.2	0.90	2.1	7.0	2.4
YB2-355S1-4	185	330	1490	95.0	0.90	2.1	7.0	2.4
YB2-355S2-4	200	356	1490	95.2	0.90	2.1	7.0	2.3
YB2-355M1-	220	443	1490	95.2	0.90	2.1	7.0	2.4
YB2-355M2-	250	442	1490	95.5	0.90	2.1	7.0	2.4
YB2-355L1-4	280	495	1490	95.5	0.90	2.1	7.0	2.4
YB2-355L2-4	315	556	1490	95.6	0.90	2.1	7.0	2.4
同步转速 1000 r/min								
YB2-711-6	0.18	0.74	850	62.0	0.66	1.9	4.0	2.1
YB2-712-6	0.25	0.95	850	63.0	0.68	1.9	4.0	2.1
YB2-801-6	0.37	1.3	850	63.0	0.70	1.9	4.0	2.1
YB2-802-6	0.55	1.8	885	66.0	0.72	1.9	4.0	2.1
YB2-90S-6	0.75	2.3	910	69.0	0.72	2.1	4.0	2.1
YB2-90L-6	1.1	3.2	910	73.0	0.73	2.1	5.0	2.1
YB2-100L-6	1.5	3.9	920	76.0	0.76	2.1	5.0	2.1
YB2-112M-6	2.2	5.6	935	79.0	0.76	2.1	5.0	2.1
YB2-132S-6	3	7.4	960	81.0	0.77	2.1	6.0	2.4
YB2-132M1-	4	9.8	960	83.0	0.78	2.1	6.0	2.4
YB2-132M2-	5.5	12.9	965	85.0	0.78	2.1	6.5	2.4
YB2-160M-6	7.5	17.2	970	86.0	0.79	2.1	6.5	2.4
YB2-160L-6	11	24.5	970	87.5	0.79	2.1	6.5	2.4
YB2-180L-6	15	31.6	970	89.0	0.81	2.1	7.0	2.1
YB2-200L1-6	18.5	38.6	980	90.0	0.83	2.2	7.0	2.4
YB2-200L2-6	22	44.7	980	90.0	0.83	2.2	7.0	2.4
YB2-225M-6	30	59.3	980	92.0	0.86	2.1	7.0	2.4
YB2-250M-6	37	71.1	980	92.0	0.86	2.1	7.0	2.4
YB2-280S-6	45	85.9	980	92.5	0.86	2.1	7.0	2.4



型号 Type	功率 kW	额定 电流 Current A	转速 r/min	效率 Eff. %	功率因数 Power Factor	堵转转矩 额定转矩 Locked Rotor Torque Rated Torque	堵转电流 额定电流 Locked Rotor Current Rated Current	最大转矩 额定转矩 Breakdown Torque Rated Torque
同步转速 1000 r/min								
YB2-280M-6	55	105	980	92.8	0.86	2.1	7.0	2.3
YB2-315S-6	75	142	985	93.5	0.86	2.0	7.0	2.2
YB2-315M-6	90	170	985	93.8	0.86	2.0	7.0	2.2
YB2-315L1-6	110	207	985	94.0	0.86	2.0	7.0	2.2
YB2-315L2-6	132	245	985	94.2	0.87	2.0	7.0	2.2
YB2-355S-6	160	292	990	94.5	0.88	2.0	7.0	2.2
YB2-355M1-	185	338	990	94.5	0.88	2.0	7.0	2.2
YB2-355M2-	200	365	990	94.7	0.88	2.0	7.0	2.2
YB2-355L1-6	220	401	990	94.7	0.88	2.0	7.0	2.2
YB2-355L2-6	250	455	990	95.0	0.88	2.0	7.0	2.2
同步转速 750 r/min								
YB2-801-8	0.18	0.88	645	52.0	0.61	1.8	3.3	1.9
YB2-802-8	0.25	1.15	645	55.0	0.61	1.8	3.3	1.9
YB2-90S-8	0.37	1.49	670	63.0	0.62	1.8	4.0	2.0
YB2-90L-8	0.55	2.17	670	64.0	0.63	1.8	4.0	2.0
YB2-100L1-8	0.75	2.4	680	71.0	0.68	1.8	4.0	2.0
YB2-100L2-8	1.1	3.4	680	73.0	0.69	1.8	4.0	2.0
YB2-112M-8	1.5	4.4	690	75.0	0.69	1.8	4.0	2.0
YB2-132S-8	2.2	6.0	705	79.0	0.73	1.8	5.5	2.2
YB2-132M-8	3	7.9	705	81.0	0.73	1.8	5.5	2.2
YB2-160M1-	4	10.3	720	81.0	0.73	1.9	6.0	2.2
YB2-160M2-	5.5	13.6	720	83.0	0.75	1.9	6.0	2.2
YB2-160L-8	7.5	17.8	720	85.0	0.76	1.9	6.0	2.2
YB2-180L-8	11	25.1	730	87.0	0.76	1.9	6.0	2.2
YB2-200L-8	15	34.1	730	89.0	0.76	2.0	6.5	2.2
YB2-225S-8	18.5	41.1	730	90.0	0.78	2.0	6.5	2.2
YB2-225M-8	22	47.4	730	90.5	0.78	2.0	6.5	2.2
YB2-250M-8	30	63.4	735	91.0	0.79	1.9	6.5	2.0
YB2-280S-8	37	77.8	735	91.5	0.79	1.8	6.0	2.0
YB2-280M-8	45	94.1	735	92.0	0.79	1.8	6.0	2.0
YB2-315S-8	55	111	735	92.8	0.81	1.9	6.5	2.2
YB2-315M-8	75	151	735	93.0	0.81	1.9	6.5	2.2
YB2-315L1-8	90	178	735	93.8	0.82	1.9	6.5	2.2
YB2-315L2-8	110	217	735	94.0	0.82	1.9	6.5	2.2
YB2-355S-8	132	261	740	94.2	0.82	2.0	6.5	2.2
YB2-355M-8	160	315	740	94.6	0.82	2.0	6.5	2.2



型号 Type	功率 kW	额定 电流 Current A	转速 r/min	效率 Eff. %	功率因数 Power Factor	堵转转矩 额定转矩 Locked Rotor Torque Rated Torque	堵转电流 额定电流 Locked Rotor Current Rated Current	最大转矩 额定转矩 Breakdown Torque Rated Torque
同步转速 750 r/min								
YB2-355L1-8	185	362	740	94.6	0.82	2.0	6.5	2.2
YB2-355L2-8	200	387	740	94.8	0.83	2.0	6.5	2.2
同步转速 600 r/min								
YB2-315S-10	45	99.6	590	92.0	0.75	1.5	6.0	2.1
YB2-315M-1	55	121	590	92.0	0.75	1.5	6.0	2.1
YB2-315L1-1	75	162	590	92.5	0.76	1.5	6.0	2.1
YB2-315L2-1	90	191	590	93.0	0.77	1.5	6.0	2.1
YB2-355S-10	90	191	590	93.0	0.77	1.5	6.0	2.1
YB2-355M1-	110	230	590	93.2	0.78	1.3	5.5	2.1
YB2-355M2-	132	275	590	93.5	0.78	1.3	5.5	2.1
YB2-355L1-1	160	333	590	93.6	0.78	1.3	5.5	2.1
YB2-355L2-1	185	385	590	93.6	0.78	1.3	5.5	2.1

常用的安装结构型式，以及适用的机座号见下表

Conventional mounting type and suitable frame size are given in following table (with “√”)

机座号 Frame	基本安装结构 Basic type			派生的安装形式 Derived type											
	B3	B5	B35	V1	V3	V5	V6	B6	B7	B8	V15	V36	B14	B34	V18
	63~71	√	√	-	√	√	√	√	√	√	√	-	-	√	√
80~112	√	√	√	√	√	√	√	√	√	√	√	√	√	√	√
132~160	√	√	√	√	√	√	√	√	√	√	√	√	-	-	-
180~280	√	√	√	√	-	-	-	-	-	-	-	-	-	-	-
315~355	√	-	√	√	-	-	-	-	-	-	-	-	-	-	-

注：“√”表示可以制造生产的结构型式。

外形及安装尺寸 Dimensions

mm

B14

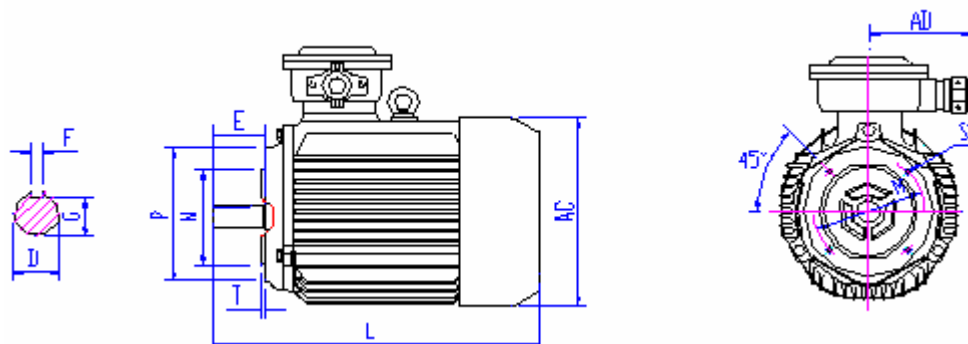



机座号 Frame	极数 Pole	安 装 尺 寸 Mounting Dimension										凸缘孔数	外形尺寸 Overall		
		D	E	F	G	M	N	P	R	S	T		AC	AD	L
63	2.4	11	23	4	8.5	75	60	90	0	M5	2.5	4	150	170	270
71	2.4.6	14	30	5	11	85	70	105	0	M6	2.5	4	155	170	300
80	2.4.6.8	19	40	6	15.5	100	80	120	0	M6	3	4	165	240	330
90S	2.4.6.8	24	50	8	20	115	95	140	0	M8	3	4	180	260	360
90L	2.4.6.8	24	50	8	20	115	95	140	0	M8	3	4	180	260	385
100L	2.4.6.8	28	60	8	24	130	110	160	0	M8	3.5	4	205	300	440
112M	2.4.6.8	28	60	8	24	130	110	160	0	M8	3.5	4	230	310	460

B34

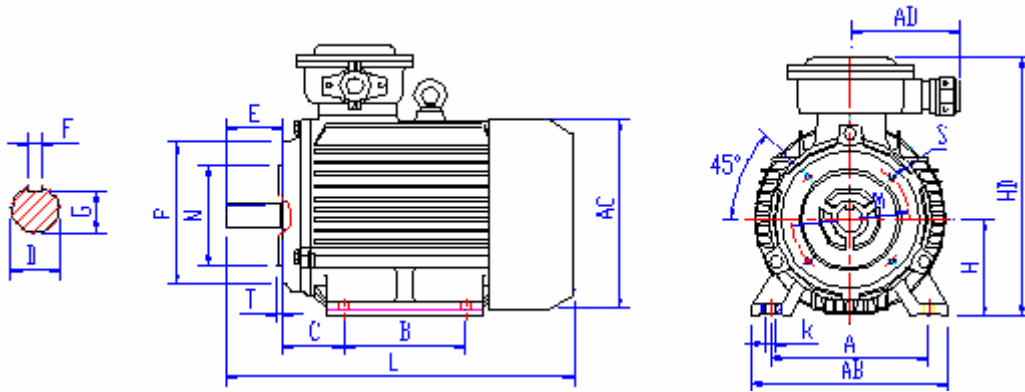

机座号 Frame	极数 Pole	安 装 尺 寸 Mounting Dimensions															外形尺寸 Overall Dimensions				
		A	B	C	D	E	F	G	H	K	M	N	P	R	S	T	AB	AC	AD	HD	L
63	2.4	100	80	40	11	23	4	8.5	63	7	75	60	90	0	M5	2.5	130	150	165	230	270
71	2.4.6	112	90	45	14	30	5	11	71	7	85	70	105	0	M6	2.5	140	155	165	240	300
80	2.4.6.8	125	100	50	19	40	6	15.5	80	10	100	80	120	0	M6	3	165	165	180	320	330
90S	2.4.6.8	140	100	56	24	50	8	20	90	10	115	95	140	0	M8	3	180	180	180	350	360
90L	2.4.6.8	140	125	56	24	50	8	20	90	10	115	95	140	0	M8	3	180	180	180	350	385
100L	2.4.6.8	160	140	63	28	60	8	24	100	12	130	110	160	0	M8	3.5	200	205	180	400	440
112M	2.4.6.8	190	140	70	28	60	8	24	112	12	130	110	160	0	M8	3.5	245	230	200	420	460



外形及安装尺寸 Dimensions

mm

B3

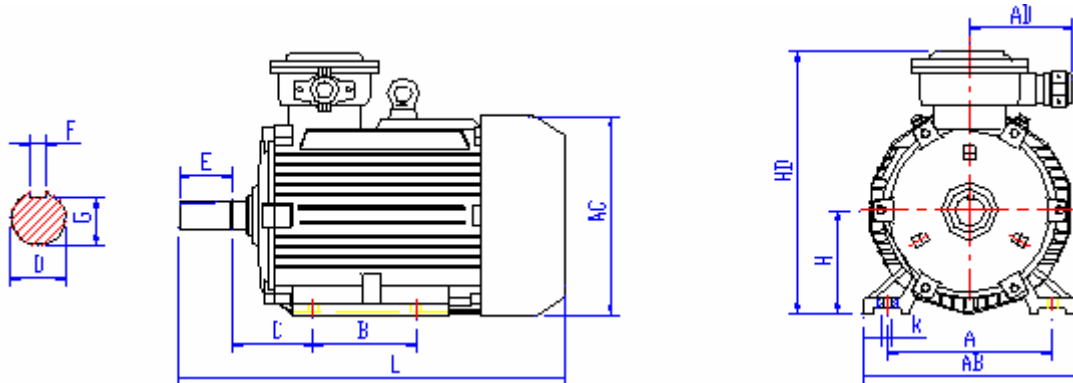

机座号 Frame	极数 Pole	安 装 尺 寸 Mounting Dimension									外 形 尺 寸 Overall Dimension				
		A	B	C	D	E	F	G	H	K	AB	AC	AD	HD	L
63	2.4	100	80	40	11	23	4	8.5	63	7	130	150	165	230	270
71	2.4.6	112	90	45	14	30	5	11	71	7	140	155	165	240	300
80	2.4.6.8	125	100	50	19	40	6	15.5	80	10	165	165	180	320	330
90S	2.4.6.8	140	100	56	24	50	8	20	90	10	180	180	180	350	360
90L	2.4.6.8	140	125	56	24	50	8	20	90	10	180	180	180	350	385
100L	2.4.6.8	160	140	63	28	60	8	24	100	12	200	205	180	400	440
112M	2.4.6.8	190	140	70	28	60	8	24	112	12	245	230	200	420	460
132S	2.4.6.8	216	140	89	38	80	10	33	132	12	280	270	200	450	510
132M	2.4.6.8	216	178	89	38	80	10	33	132	12	280	270	200	450	550
160M	2.4.6.8	254	210	108	42	110	12	37	160	15	330	325	220	520	655
160L	2.4.6.8	254	254	108	42	110	12	37	160	15	330	325	220	520	695
180M	2.4.6.8	279	241	121	48	110	14	42.5	180	15	355	360	220	550	730
180L	2.4.6.8	279	279	121	48	110	14	42.5	180	15	355	360	220	550	750
200L	2.4.6.8	318	305	133	55	110	16	49	200	19	390	400	250	645	805
225S	4.8	356	286	149	60	140	18	53	225	19	435	450	250	690	865
225M	2	356	311	149	55	110	16	49	225	19	435	450	250	690	860
	4.6.8				60	140	18	53							890
250M	2	406	349	168	60	140	18	53	250	24	490	500	300	720	945
	4.6.8				65	140	18	58							
280S	2	457	368	190	65	140	18	58	280	24	545	560	300	790	1010
	4.6.8				75	140	20	67.5							
280M	2	457	419	190	65	140	18	58	280	24	545	560	300	790	1060
	4.6.8				75	140	20	67.5							
315S	2	508	406	216	65	140	18	58	315	28	640	630	400	1020	1250
	4.6.8.10				80	170	22	71							1280
315M	2	508	457	216	65	140	18	58	315	28	640	630	400	1020	1320
	4.6.8.10				80	170	22	71							1350
315L	2	508	508	216	65	140	18	58	315	28	640	630	400	1020	1410
	4.6.8.10				80	170	22	71							1440



机座号 Frame	极数 Pole	安 装 尺 寸 Mounting Dimension									外 形 尺 寸 Overall Dimension				
		A	B	C	D	E	F	G	H	K	AB	AC	AD	HD	L
355S	2	610	500	254	75	140	20	67.5	355	28	740	750	500	1080	1510
	4.6.8.10				95	170	25	86							
355M	2	610	560	254	75	140	20	67.5	355	28	740	750	500	1080	1570
	4.6.8.10				95	170	25	86							
355L	2	610	630	254	75	140	20	67.5	355	28	740	750	500	1080	1690
	4.6.8.10				95	170	25	86							

外形及安装尺寸 Dimensions

mm

B5

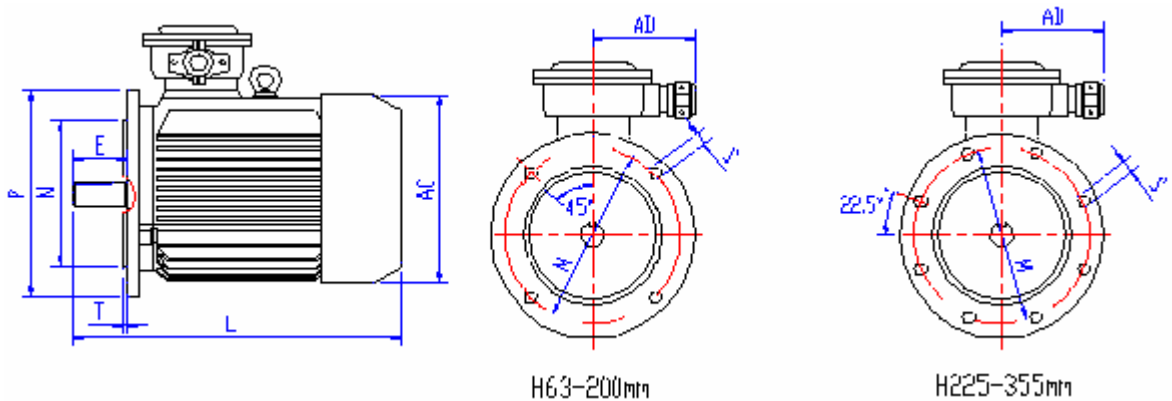

H63-200mm

H225-355mm

机座号 Frame	极数 Pole	安 装 尺 寸 Mounting Dimension											外 形 尺 寸 Overall			
		D	E	F	G	M	N	P	R	S	T	凸缘孔数	AC	AD	L	
		卧式		立式												
63	2.4	11	23	4	8.5	115	95	140	0	10	3.0	4	130	170	270	-
71	2.4.6	14	30	5	11	130	110	160	0	10	3.0	4	145	170	300	-
80	2.4.6.8	19	40	6	15.5	165	130	200	0	12	3.5	4	165	240	330	-
90S	2.4.6.8	24	50	8	20	165	130	200	0	12	3.5	4	180	260	360	-
90L	2.4.6.8	24	50	8	20	165	130	200	0	12	3.5	4	180	260	385	-
100L	2.4.6.8	28	60	8	24	215	180	250	0	15	4	4	205	300	440	-
112M	2.4.6.8	28	60	8	24	215	180	250	0	15	4	4	230	310	460	-
132S	2.4.6.8	38	80	10	33	265	230	300	0	15	4	4	270	320	510	-
132M	2.4.6.8	38	80	10	33	265	230	300	0	15	4	4	270	320	550	-
160M	2.4.6.8	42	110	12	37	300	250	350	0	19	5	4	325	360	655	-
160L	2.4.6.8	42	110	12	37	300	250	350	0	19	5	4	325	360	695	-
180M	2.4.6.8	48	110	14	42.5	300	250	350	0	19	5	4	360	370	730	800
180L	2.4.6.8	48	110	14	42.5	300	250	350	0	19	5	4	360	370	750	820
200L	2.4.6.8	55	110	16	49	350	300	400	0	19	5	4	400	445	805	875
225S	4.8	60	140	18	53	400	350	450	0	19	5	8	450	465	865	935
225M	2	55	110	16	49	400	350	450	0	19	5	8	450	465	860	930
	4.6.8	60	140	18	53										890	960
250M	2	60	140	18	53	500	450	550	0	19	5	8	500	500	945	1035
	4.6.8	65	140	18	58											



机座号 Frame	极数 Pole	安 装 尺 寸 Mounting Dimension											外 形 尺 寸 Overall			
		D	E	F	G	M	N	P	R	S	T	凸缘孔数	AC	AD	L	
															卧式	立式
280S	2	65	140	18	58	500	450	550	0	19	5	8	560	550	1010	1100
	4.6.8	75	140	20	67.5											
280M	2	65	140	18	58	500	450	550	0	19	5	8	560	550	1060	1150
	4.6.8	75	140	20	67.5											
315S	2	65	140	18	58	600	550	660	0	24	6	8	630	705	-	1340
	4.6.8.10	80	170	22	71											1370
315M	2	65	140	18	58	600	550	660	0	24	6	8	630	705	-	1420
	4.6.8.10	80	170	22	71											1450
315L	2	65	140	18	58	600	550	660	0	24	6	8	630	705	-	1510
	4.6.8.10	80	170	22	71											1540
355S	2	75	140	20	67.5	740	680	800	0	24	6	8	750	725	-	1600
	4.6.8.10	95	170	25	86											
355M	2	75	140	20	67.5	740	680	800	0	24	6	8	750	725	-	1600
	4.6.8.10	95	170	25	86											
355L	2	75	140	20	67.5	740	680	800	0	24	6	8	750	725	-	1780
	4.6.8.10	95	170	25	86											

外形及安装尺寸 Dimensions

mm

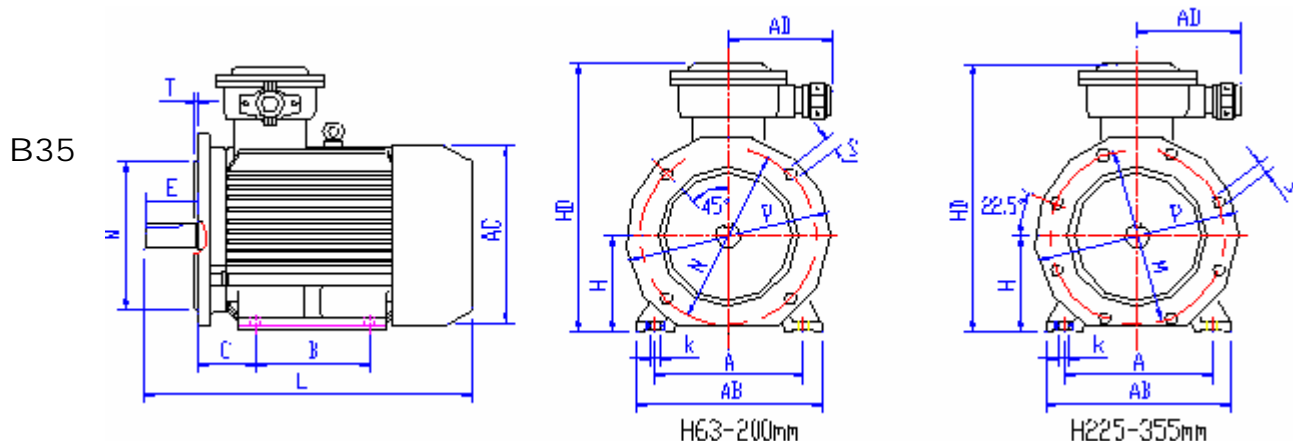

机座号 Pole	极数	安 装 尺 寸 Mounting Dimension															外 形 尺 寸 Overall					
		A	B	C	D	E	F	G	H	K	M	N	P	R	S	T	凸	AB	AC	AD	HD	L
80	2.4.6.8	125	100	50	19	40	6	15.5	80	10	165	130	200	0	12	3.5	4	165	165	180	320	330
90S	2.4.6.8	140	100	56	24	50	8	20	90	10	165	130	200	0	12	3.5	4	180	180	180	350	360
90L	2.4.6.8	140	125	56	24	50	8	20	90	10	165	130	200	0	12	3.5	4	180	180	180	350	385
100L	2.4.6.8	160	140	63	28	60	8	24	100	12	215	180	250	0	15	4	4	200	205	180	400	440
112M	2.4.6.8	190	140	70	28	60	8	24	112	12	215	180	250	0	15	4	4	245	230	200	420	460
132S	2.4.6.8	216	140	89	38	80	10	33	132	12	265	230	300	0	15	4	4	280	270	200	450	510
132M	2.4.6.8	216	178	89	38	80	10	33	132	12	265	230	300	0	15	4	4	280	270	200	450	550



机座号	极数 Pole	安 装 尺 寸 Mounting Dimension																外形尺寸 Overall				
		A	B	C	D	E	F	G	H	K	M	N	P	R	S	T	凸	AB	AC	AD	HD	L
160M	2.4.6.8	254	210	108	42	110	12	37	160	15	300	250	350	0	19	5	4	330	325	220	520	655
160L	2.4.6.8	254	254	108	42	110	12	37	160	15	300	250	350	0	19	5	4	330	325	220	520	695
180M	2.4.6.8	279	241	121	48	110	14	42.5	180	15	300	250	350	0	19	5	4	355	360	220	550	730
180L	2.4.6.8	279	279	121	48	110	14	42.5	180	15	300	250	350	0	19	5	4	355	360	220	550	750
200L	2.4.6.8	318	305	133	55	110	16	49	200	19	350	300	400	0	19	5	4	390	400	250	645	805
225S	4.8	356	286	149	60	140	18	53	225	19	400	350	450	0	19	5	8	435	450	250	690	865
225M	2	356	311	149	55	110	16	49	225	19	400	350	450	0	19	5	8	435	450	250	690	860
	4.6.8				60	140	18	53														890
250M	2	406	349	168	60	140	18	53	250	24	500	450	550	0	19	5	8	490	500	300	720	945
	4.6.8				65	140	18	58														
280S	2	457	368	190	65	140	18	58	280	24	500	450	550	0	19	5	8	545	565	300	790	1010
	4.6.8				75	140	20	67.5														
280M	2	457	419	190	65	140	18	58	280	24	500	450	550	0	19	5	8	545	565	300	790	1060
	4.6.8				75	140	20	67.5														
315S	2	508	406	216	65	140	18	58	315	28	600	550	660	0	24	6	8	640	630	400	1020	1250
	4.6.8.10				80	170	22	71														1280
315M	2	508	457	216	65	140	18	58	315	28	600	550	660	0	24	6	8	640	630	400	1020	1320
	4.6.8.10				80	170	22	71														1350
315L	2	508	508	216	65	140	18	58	315	28	600	550	660	0	24	6	8	640	630	400	1020	1410
	4.6.8.10				80	170	22	71														1440
355S	2	610	500	254	75	140	20	67.5	355	28	740	680	800	0	24	6	8	740	750	500	1080	1510
	4.6.8.10				95	170	25	86														
355M	2	610	560	254	75	140	20	67.5	355	28	740	680	800	0	24	6	8	740	750	500	1080	1570
	4.6.8.10				95	170	25	86														
355L	2	610	630	254	75	140	20	67.5	355	28	740	680	800	0	24	6	8	740	750	500	1080	1690
	4.6.8.10				95	170	25	86														